

4. Application Circuits

	page
4.1 Output voltage trimming for DBS/CDS	D-1
4.2 Remote ON/OFF circuit for DBS/CDS	D-3
4.3 Current source operation for DBS/CDS	D-5
4.4 O.C.P. (Over Current Protection) point adjust. for DBS/CDS	D-6
4.5 Inrush current limiting for CBS	D-7
4.6 Surge protection circuit	D-8

4.1 Output voltage trimming for DBS/CDS

- Adjusting method by applying external voltage.
By applying the voltage to TRM pin, output voltage can be adjusted.

Output voltage $V_o[V] = \text{External voltage } V_i[V] \times \text{Rated output voltage}[V]$

Fig.4.1.1 is basic connection of output voltage control. Fig.4.1.2 is output voltage characteristic of the trimming circuit.

Fig.4.1.1
Output voltage
trimming (basic)

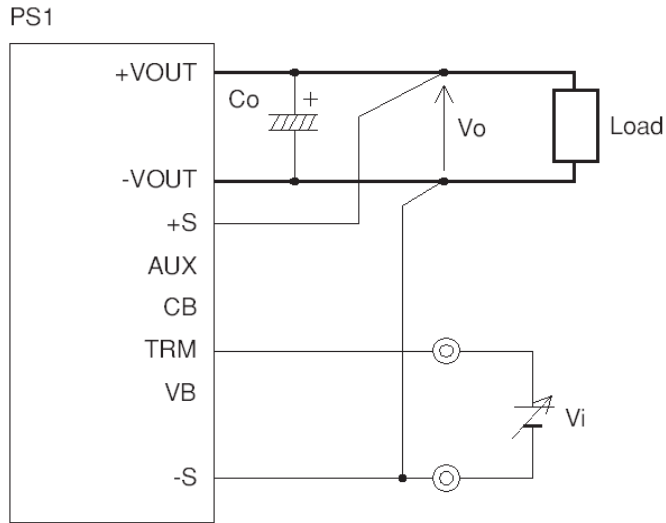
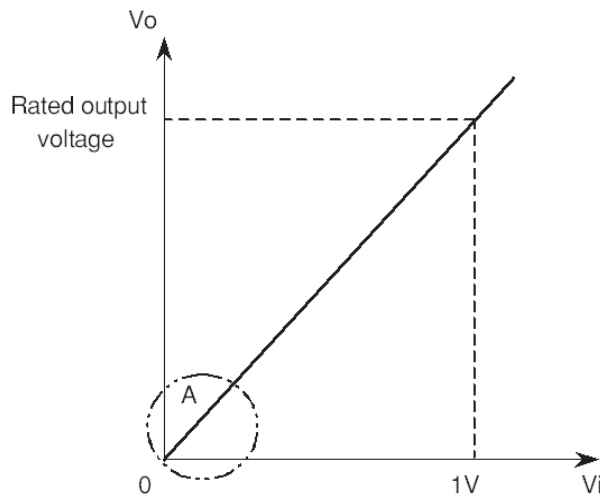

Fig.4.1.2
Voltage trimming
characteristic



* If output voltage is trimmed down below 60% of the rated output voltage, ripple and noise will increase occasionally and/or over shoot occurs when start-up. External filter attached to the output is effective to avoid over shoot when start-up.

- In connection as shown in Fig.4.1.1, output voltage can not reach zero completely made. In case of 12V output module, it remains approximately 0.1-0.2V.

The characteristics can be improved by connecting AUX and CB, and connecting TRM and -S as shown in Fig.4.1.3.

Fig.4.1.3
Output voltage
trimming
(improvement)

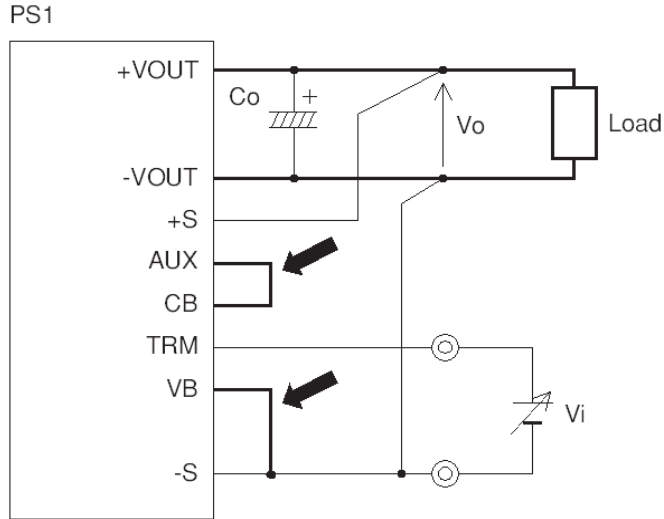
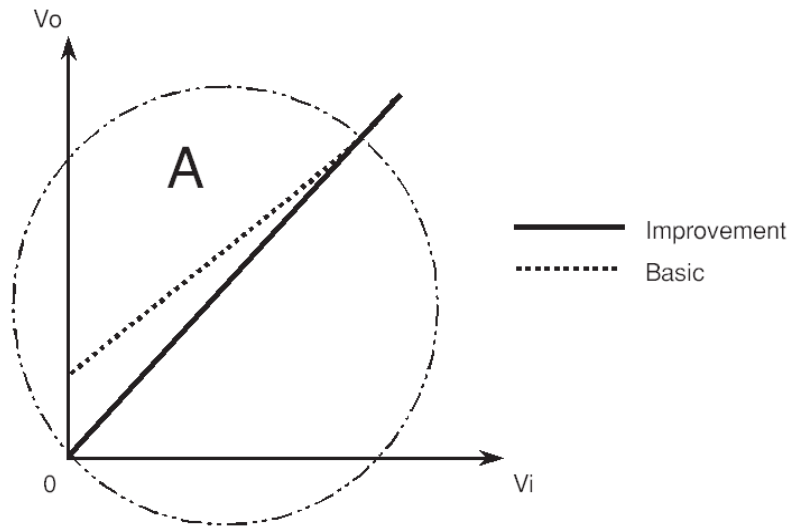

Fig.4.1.4
Voltage trimming
characteristic
(enlarge the A)



4.2 Remote ON/OFF circuit for DBS/CDS

(1) Remote ON/OFF circuit at output side in series and parallel operation

- Please refer to item 1.7 and 3.7 for a basic circuit structure.
 - Remote ON/OFF circuit (RC2, RC3) is isolated from input and output circuit. Therefore, the modules can be controlled by easy connections.
 - When auxiliary power source (AUX pin) is available for Remote ON/OFF by connecting the modules as shown in Fig.4.2.1 and Fig.4.2.2.
- The maximum operative number of units is 3 in series operation.

Fig.4.2.1
Remote ON/OFF of
series operation

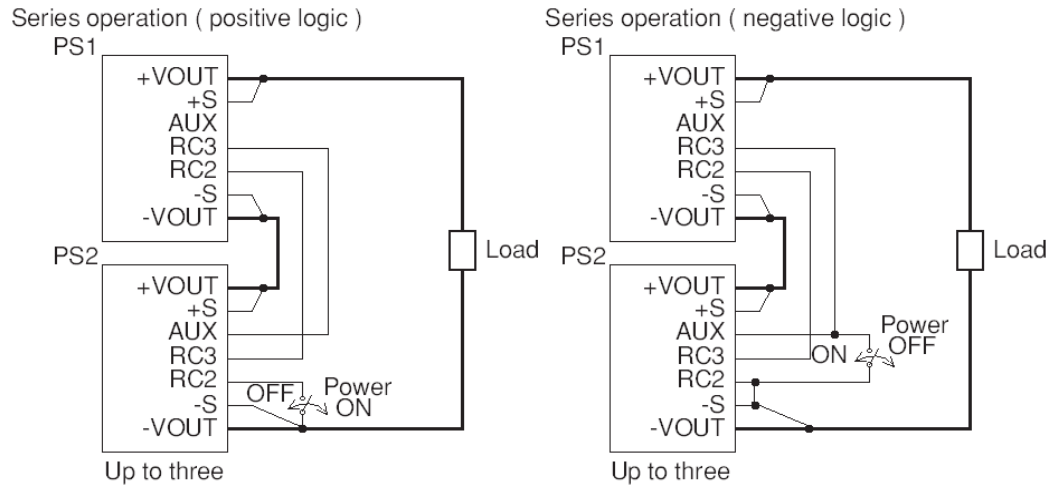
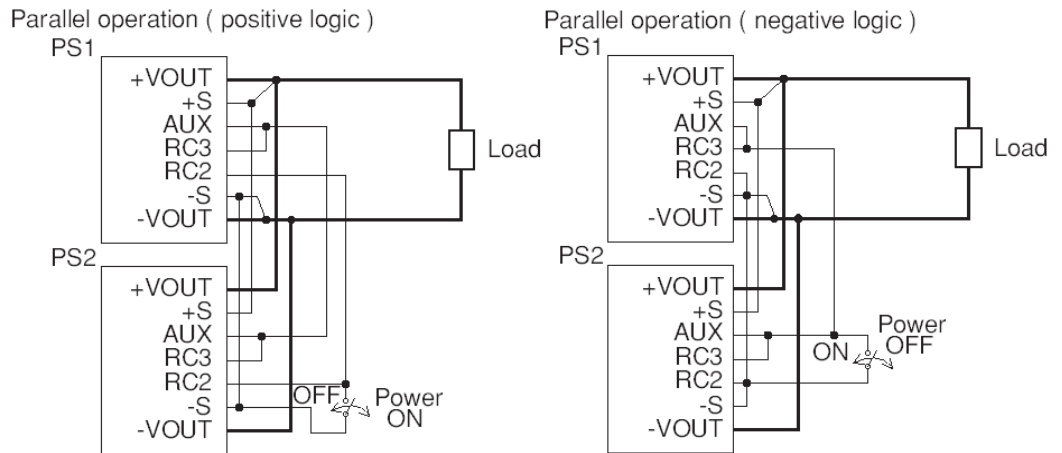

Fig.4.2.2
Remote ON/OFF of
parallel operation



- An external power supply can be used for Remote ON/OFF by connecting the modules as shown in Fig.4.2.3 and Fig.4.2.4.

Current limiting resistance R must be required.

The limit resistor can be calculated by the following equation.

$$R[\Omega] = \frac{(V_{cc} - 1.1) \times 500 - 150}{N}$$

N : Number of modules

The dissipated power of the limit resistor can be calculated by the following equation.

$$P_R[W] = \frac{(V_{cc})^2}{R}$$

Fig.4.2.3
Remote ON/OFF of series operation

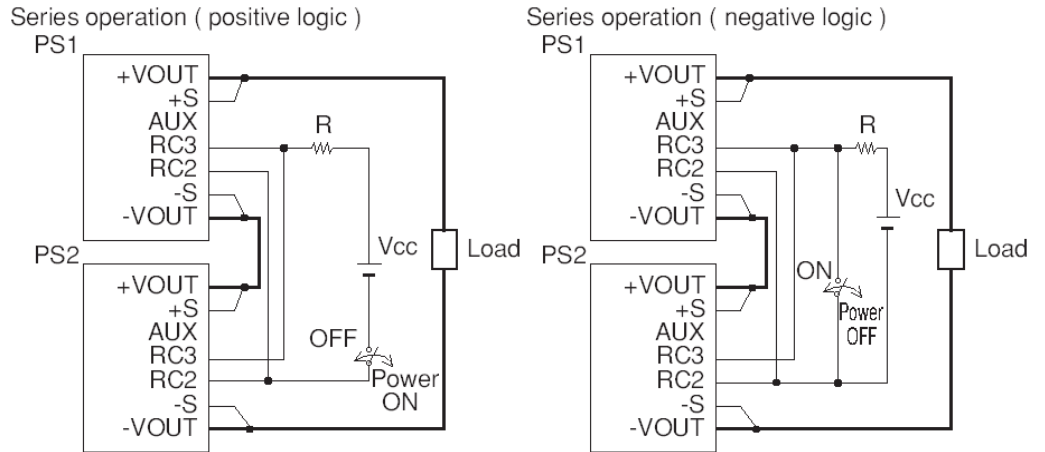
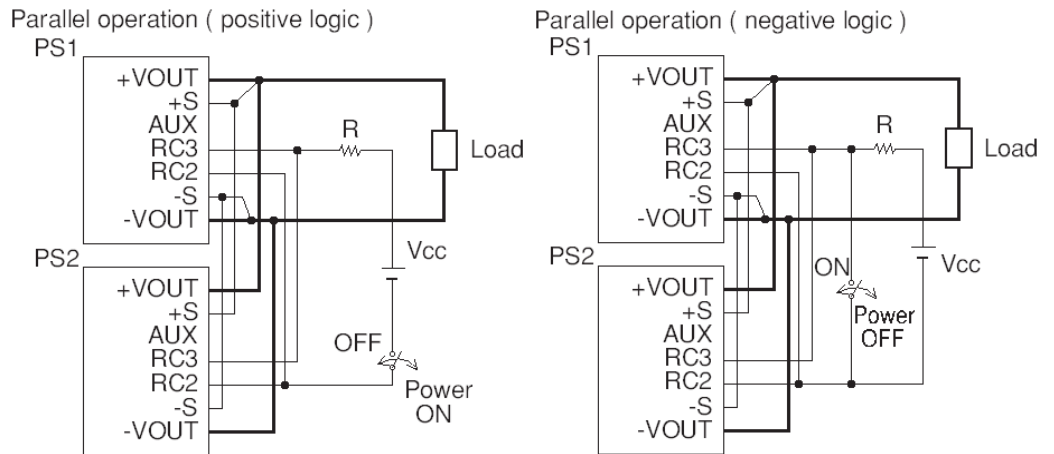

Fig.4.2.3
Remote ON/OFF of series operation



(2) Applications of Remote ON/OFF

- Remote ON/OFF circuit is built-in on both side of input (RC1) and output (RC2, RC3).

Table 4.2.1 shows the application of Remote ON/OFF.

Table 4.2.1
Application of remote ON/OFF

No	Remote ON/OFF pin	Application
1	RC1 (input side)	Remote ON/OFF on the input side Shutdown in abnormal circumstances
2	RC2, RC3 (output side)	Remote ON/OFF on the output side

4.3 Current source operation for DBS/CDS

Fig.4.3.1
Example of current source by DBS/CDS

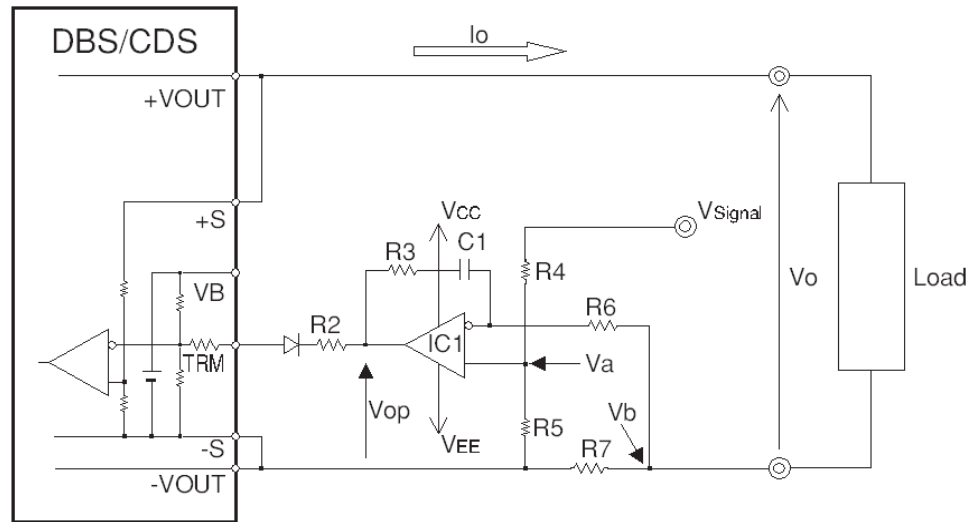

- Operation like current source is possible by external circuit in Fig.4.3.1. Behavior by circuit is refer to Fig.4.3.2.

Fig.4.3.2
Behavior of current source

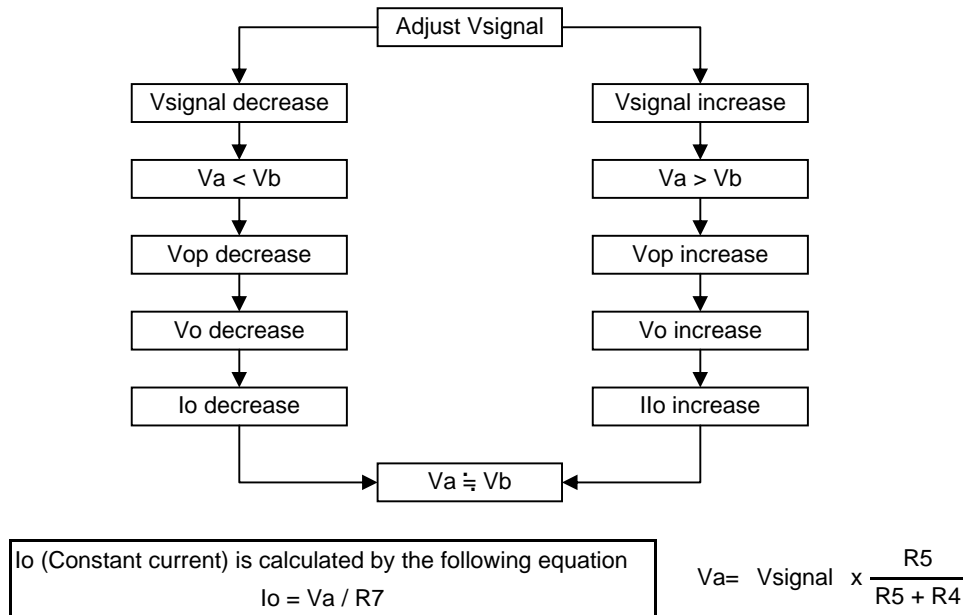

[Notice]

- (1) R7 should be a high accuracy resistor.
- (2) Output characteristics is determined by R3, R6 and C1 with consideration.

Ex. R3 = 10 [kΩ]
R6 = 1 [kΩ]
C1 = 1 [μF]

- (3) R4 and R5 are calculated by the following equation.

$$\frac{R5}{R5 + R4} \cong \frac{I_o}{V_{signal}} \times R7$$

Please evaluate under end-use condition before using.

4.4 O.C.P. (Over Current Protection) point adjustment for DBS/CDS

- O.C.P. point can be adjusted by external circuit in Fig.4.4.1.
- Component value in Table 4.4.1 may set the O.C.P. point range at 30% to 105% of rated current.

O.C.P. characteristics is straight-line current limiting type, recovers automatically when the fault condition is removed.

Fig.4.4.1
Output current
adjusting circuit

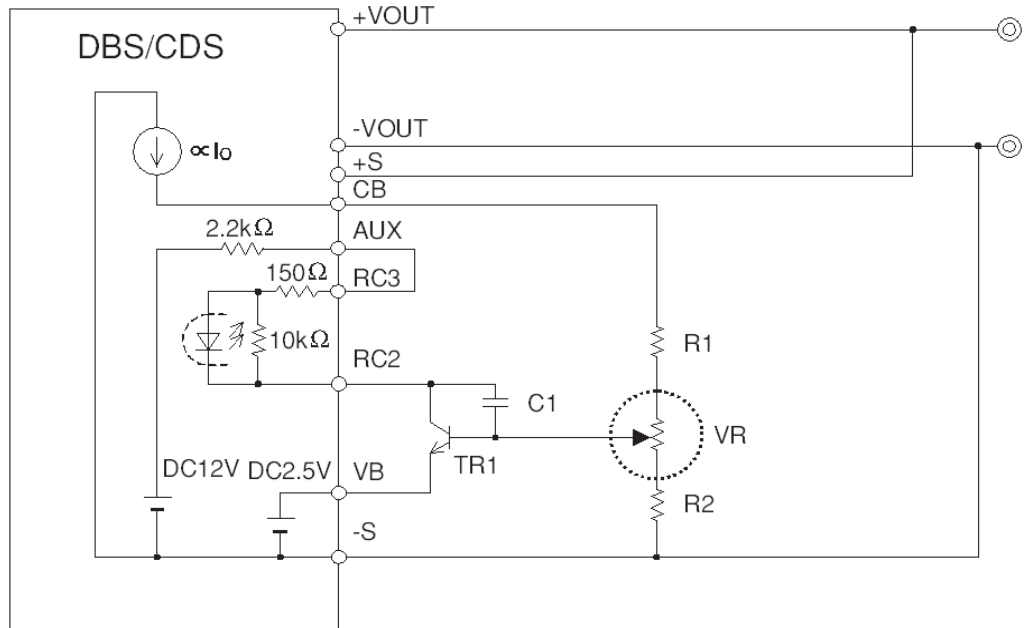

Table 4.4.1
Example of value

No	Parts No	Value/model name	Remarks
1	C1	0.1μF	
2	R1	4.7kΩ	
3	R2	10kΩ	
4	VR	10kΩ	
5	TR1	2SC1815	Manufacture : Toshiba

Applications

- (1) To make pattern wise on P.C.B., value of parts, etc. well suited for actual output power.
- (2) For gilding machine, water resolving machine, battery charger.

4.5 Inrush current limiting for CBS

- Large input capacitors is required for stable operation of DC-DC converter. The inrush current caused by this capacitor could be large.

Fig.4.5.1 shows the inrush current when an inrush limiting circuit is not installed.

- To reduce the inrush current, install an inrush limiting circuit shown in Fig.4.5.2.
- Fig.4.5.2 shows the inrush current when an inrush limiting circuit is installed.

Fig.4.5.1
Inrush current of normal circuit

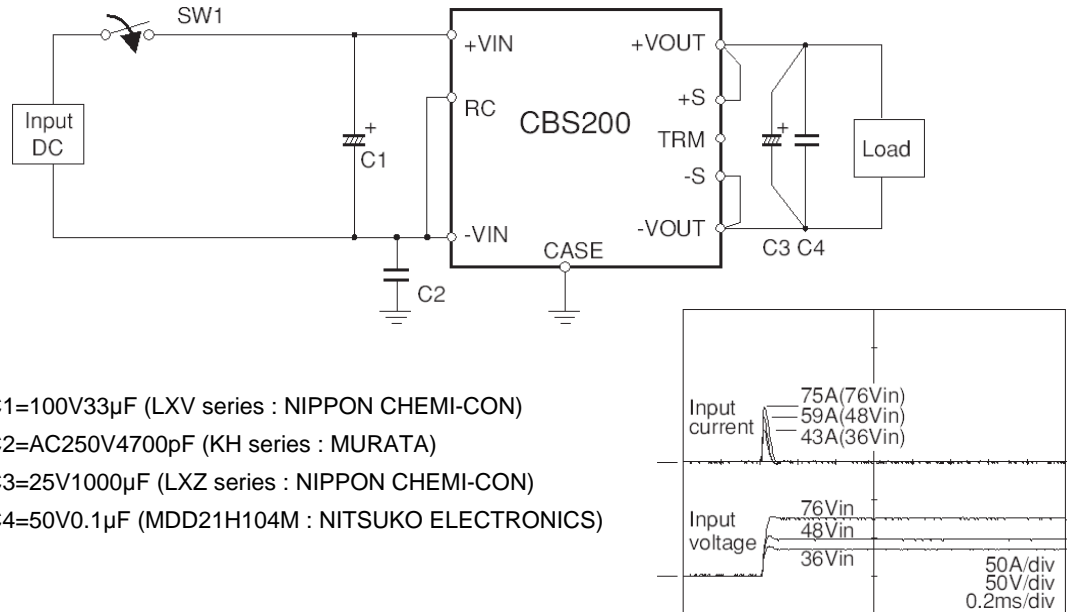
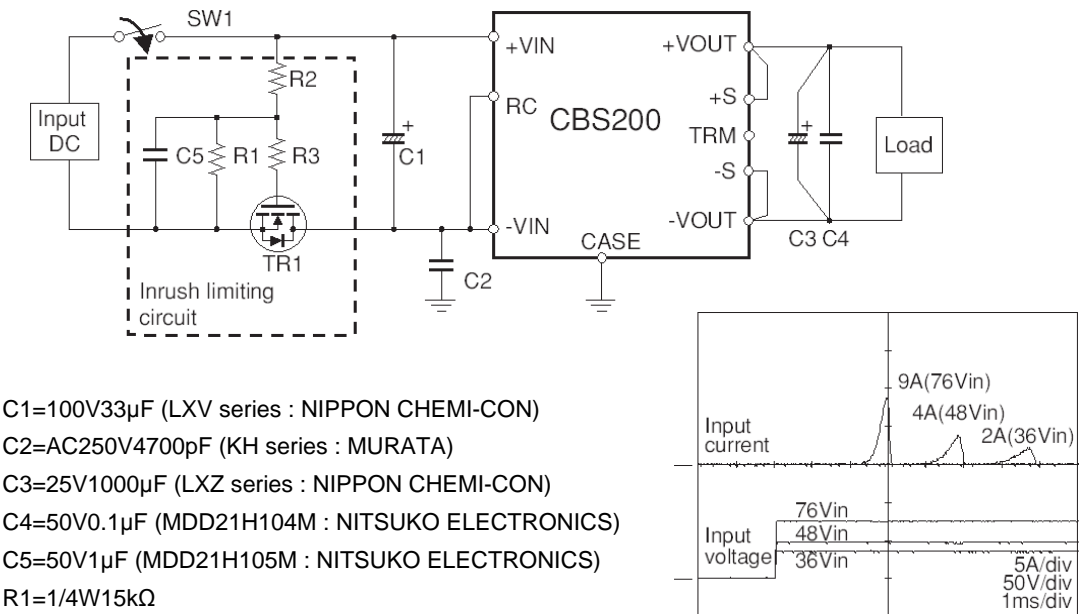
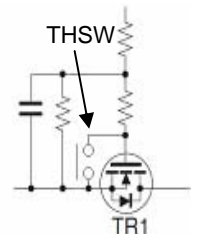

Fig.4.5.2
Inrush current limiting circuit



- Since TR1 is on input line, if TR1 failed by some reason, it could generate heat. Therefore, please consider some protection such as "overheat protection device".
 Ex.) Add "Thermal SW" to TR1 and connect it in between Gste and Source.



4.6 Surge protection circuit

- The surge protection circuit for Railway application is shown in Fig.4.6.1.
(for RIA12 or EN50155)

Fig.4.6.1
Surge protection
circuit

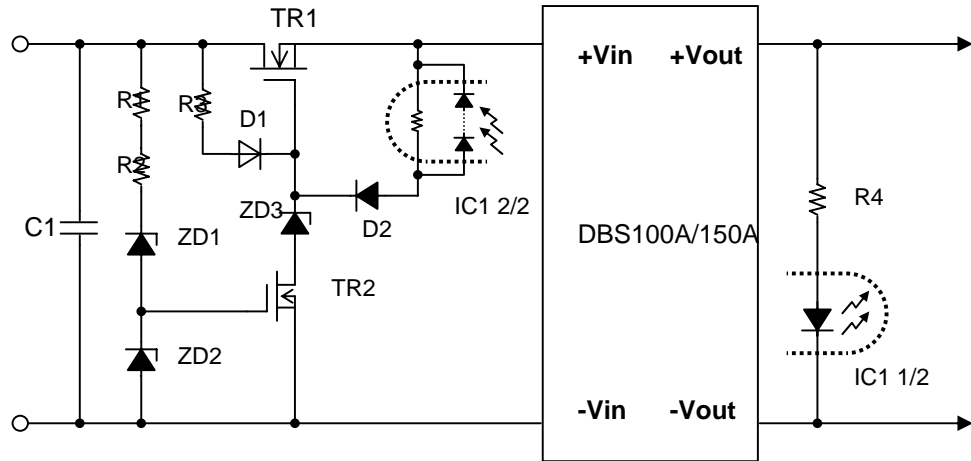
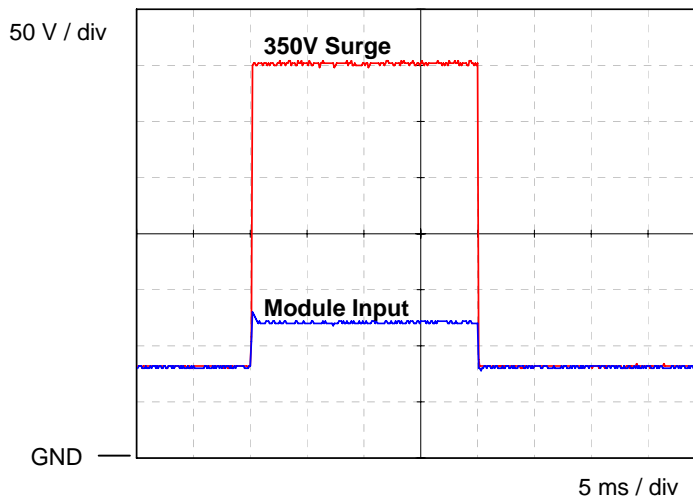

Table 4.6.1
Example of value

C1	400V, 1 μ F	ZD1	1/2W, 160V
R1	1/4W, 22k Ω	ZD2	1/4W, 10V
R2	1/4W, 22k Ω	ZD3	1/2W, 160V
R3	1/4W, 33k Ω	IC1	TLP591B (TOSHIBA)
D1	1N4148	TR1	IRFP450
D2	1N4148	TR2	IRFD110
R4	1/4W, (Output voltage / 5) k Ω		

Fig.4.6.2
Clamped surge
voltage



- Input transient surge voltage (20 ms max) is clamped to the module's input range, through the circuit in Fig.4.6.1.