

## 6. DPF and DPA series

	page
<b>6.1 Overview</b>	F-1
<b>6.2 Connection for standard use</b>	F-4
6.2.1 When the output power is over 400W	F-4
6.2.2 When the output power is 400W or less	F-5
<b>6.3 Wiring input / output pin</b>	F-5
6.3.1 Wiring input pin	F-5
6.3.2 Wiring output pin	F-7
<b>6.4 Function</b>	F-11
6.4.1 Protection circuit	F-11
6.4.2 Control signals	F-11
6.4.3 Others	F-12
<b>6.5 Series and parallel operation</b>	F-13
6.5.1 Series operation	F-13
6.5.2 Parallel operation	F-13
6.5.3 N+1 redundant operation	F-15
<b>6.6 EMI</b>	F-15

## 6.1 Overview

- DPF1000 and DPA500F are AC-DC front-end modules for DBS series. These modules have the power factor correction and the harmonic current reduction function.
- DPF1000 is able to output 1000W (AC100V) /1500W (AC200V), and DPA500F is able to output 500W (AC100V) /750W (AC200V). When DBS module's efficiency is 80%, 800W (AC100V) /1200W (AC200V) power supply system can be configured by using DPF1000.
- The power factor correction circuit of DPF1000 and DPA500F consist of boost converter. The output voltage is higher than the input voltage. When power factor correction function is disabled, rectified input voltage can still be present at the module output.
- DPF1000 and DPA500F provide control signals for system design, these signals control the DBS operation as shown in Fig.6.1.5.

Fig.6.1.1  
Input current waveform  
(DPF1000 AC100V)

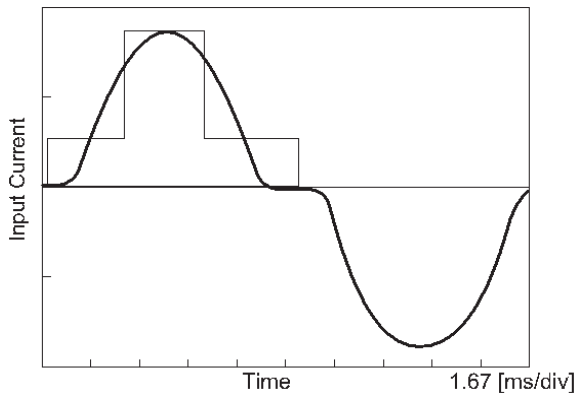

Fig.6.1.2  
Harmonics current  
(DPF1000 AC100V)

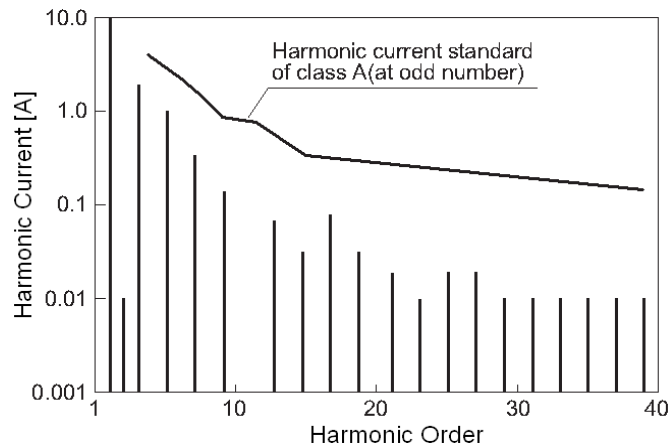
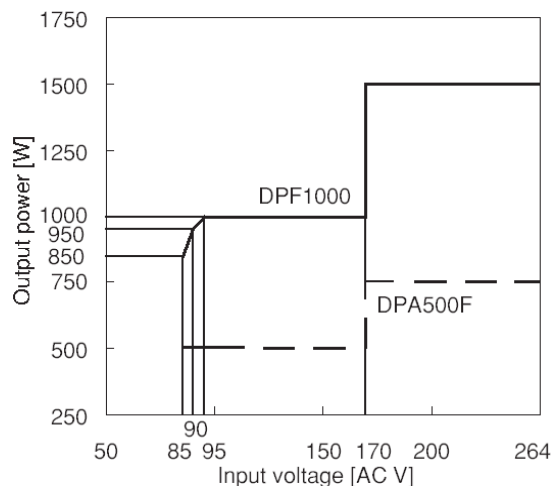

Fig.6.1.3  
Maximum output power  
by Input voltage



# DPF and DPA series

Fig.6.1.4  
Output voltage  
(Actual data)

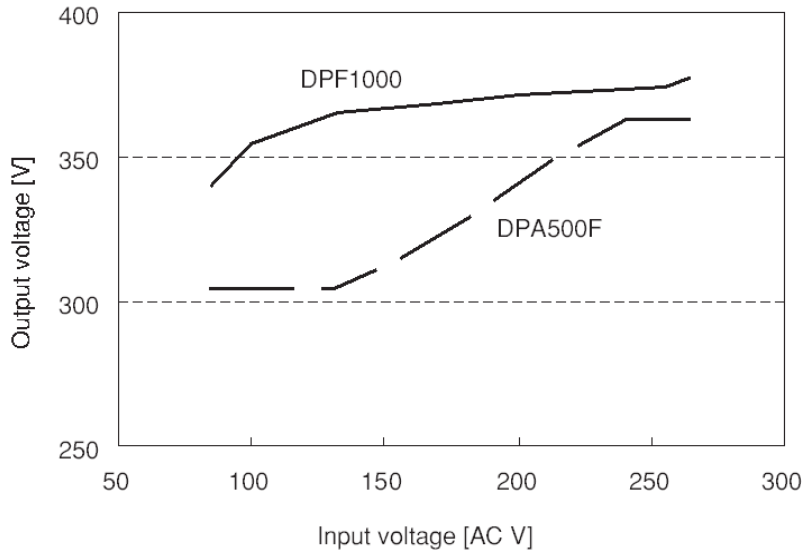
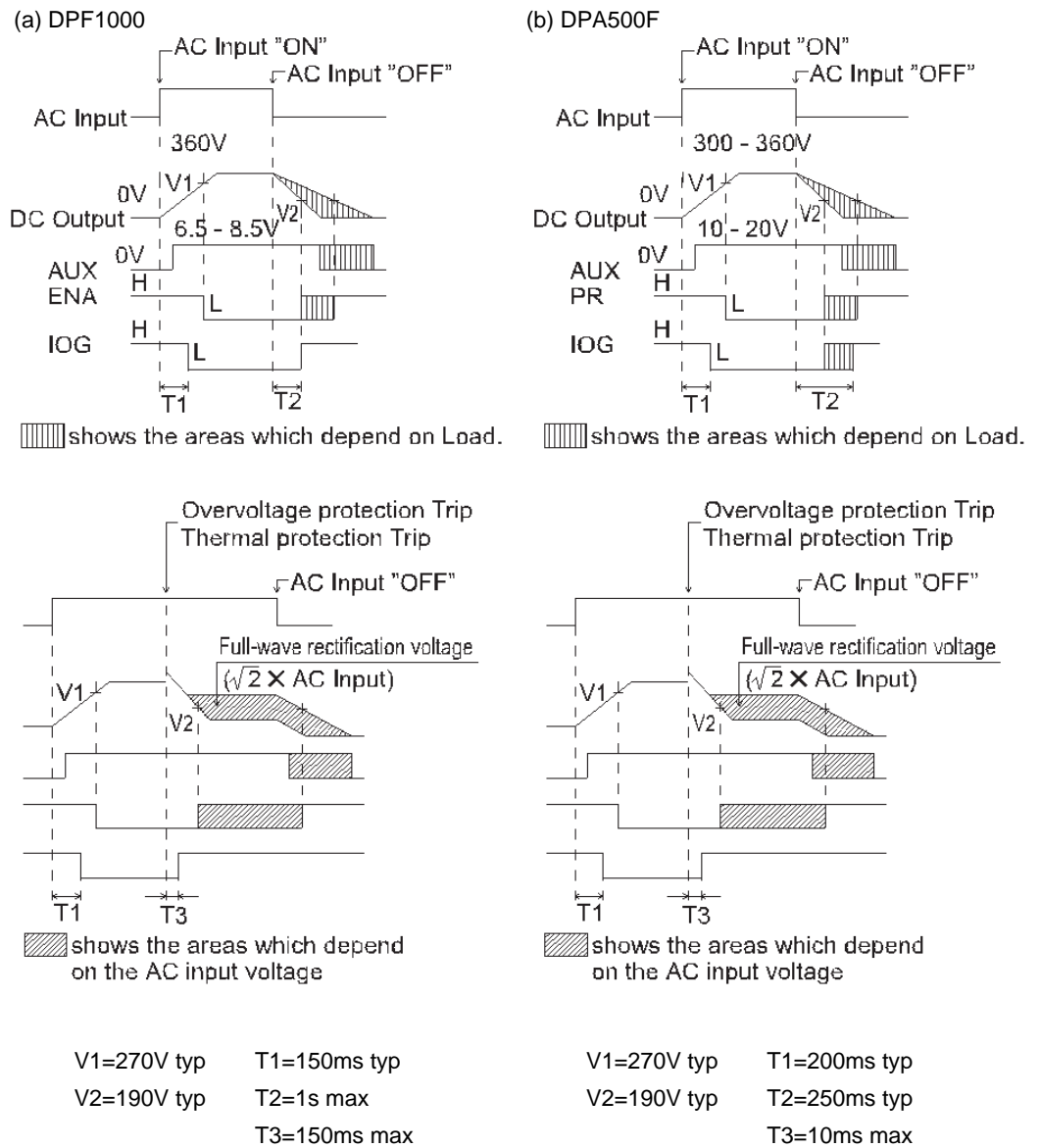

Fig.6.1.5  
Sequence chart



# DPF and DPA series

Fig.6.1.6  
Pin configuration  
(bottom view)

(a) DPF1000

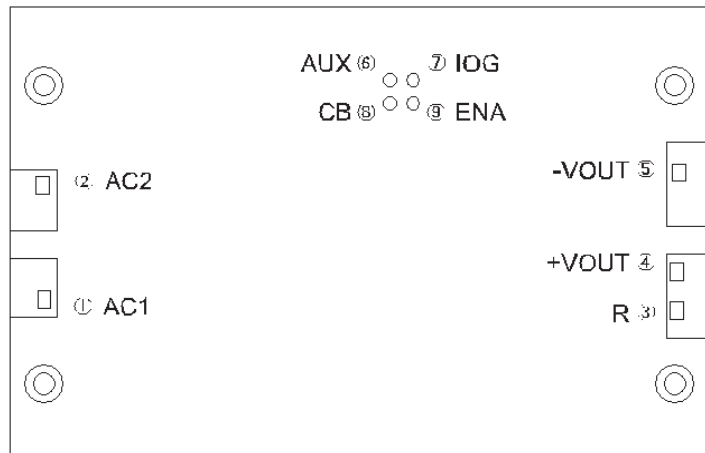

(b) DPA500F

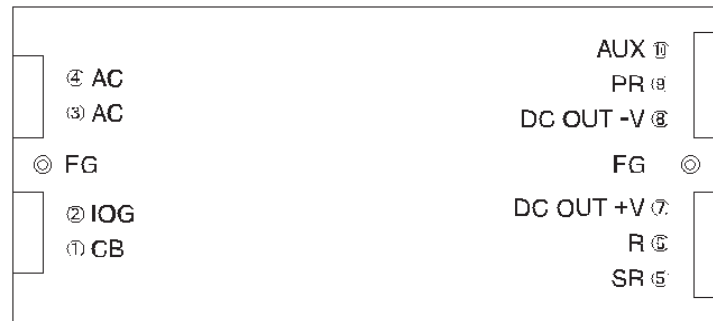

Table 6.1.1  
Pin configuration and  
function (DPF1000)

Pin №	Pin Name	Function	Reference
①	AC1	AC input	6.3.1 Wiring input pin
②	AC2		
③	R	External resistor for inrush current protection	6.3.2 Wiring output pin
④	+VOUT	+DC output	
⑤	-VOUT	-DC output	
⑥	AUX	Auxiliary power supply for external signal	6.4.2 Control signals
⑦	IOG	Inverter operation monitor	
⑧	CB	Current balance	6.5.2 Parallel operation
⑨	ENA	Enable signal	6.4.2 Control signals
-	FG	Frame ground	6.3 Wiring input / output pin

Table 6.1.2  
Pin configuration and  
function (DPA500F)

Pin №	Pin Name	Function	Reference
①	CB	Current balance	6.5.2 Parallel operation
②	IOG	Inverter operation monitor	6.4.2 Control signals
③	AC	AC input	6.3.1 Wiring input pin
④	AC		
⑤	SR	Inrush current protection	6.3.2 Wiring output pin
⑥	R	External resistor for inrush current protection	
⑦	DC OUT +V	+DC output	
⑧	DC OUT -V	-DC output	
⑨	PR	Power ready signal	6.4.2 Control signals
⑩	AUX	Auxiliary power supply for external signal	
-	FG	Frame ground	6.3 Wiring input / output pin

## 6.2 Connection for standard use

- DPF1000 and DPA500F must be used with some external components (fuse, noise filter, inrush current limiting resistor and heat sink).

### 6.2.1 When the output power is exceed 400W

- Use the DPF1000 as shown in Fig.6.2.1 for applications require 400W or more from the power supply system.
- DPF1000 is non-isolated between input and output.
- The power supply adopts the conduction cooling system. Attach a heat sink onto the aluminum base plate to cool the power module for use.

Fig.6.2.1  
Example of connection  
circuit, DPF1000/DBS

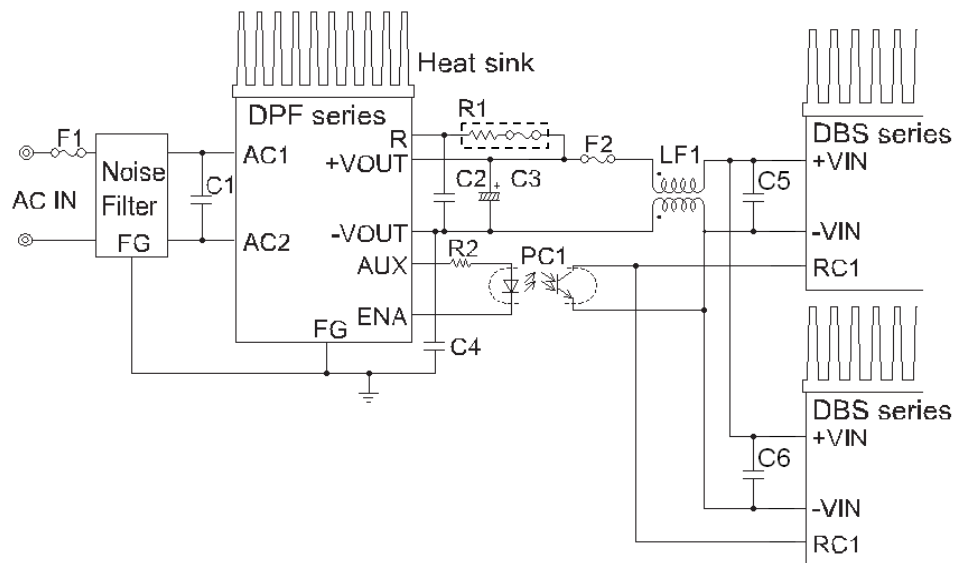

## 6.2.2 When the output power is up to 400W

- Use the DPA500F as shown in Fig.6.2.2 for applications requiring less than 400W from the power supply system.
- DPA500F is non-isolated between input and output.
- The power supply adopts the conduction cooling system. Attach a heat sink onto the aluminum base plate to cool the power module for use.

Fig.6.2.2  
Example of connection  
circuit, DPA500F/DBS

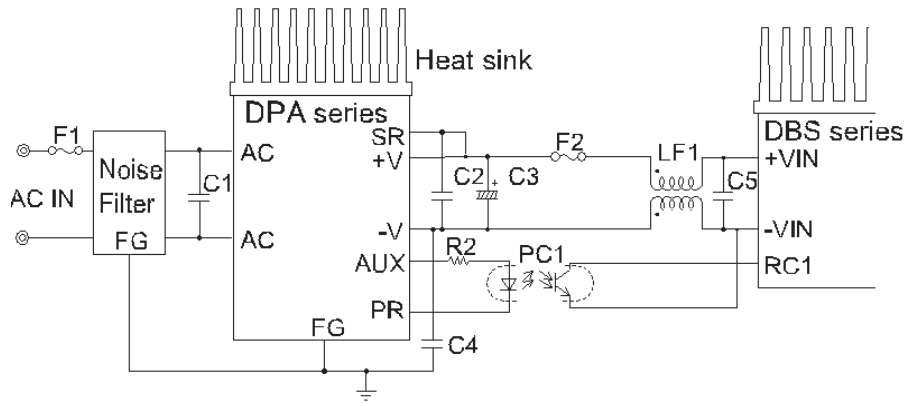

## 6.3 Wiring input / output pin

### 6.3.1 Wiring input pin

(1) Input fuse F1

- Fuse is not built-in at input side. In order to secure the safety of the unit, use the slow-blow type fuse as shown in Table 6.3.1 on the input line.
- When two or more units are used, such as a parallel operation, install a fuse for each unit.

Table 6.3.1  
Input fuse

No	Module	Recommended fuse	
		AC100V	AC200V
1	DPA500F	10A / AC250V	7.5A / AC250V
2	DPF1000	20A / AC250V	15A / AC250V

(2) Noise filter NF1

- Noise filter is not built-in at input side. Install an external noise filter to reduce the line-noise and to keep stable operation of the module.
- Install a correspondence filter as shown in chapter 6.6, if a EMI standard is required.

Fig.6.3.1  
Recommended filter  
for DPA500F

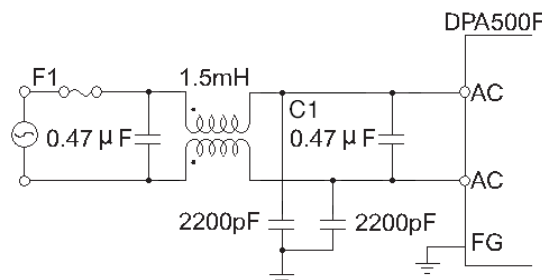

# DPF and DPA series

Fig.6.3.2  
Recommended filter  
for DPF1000

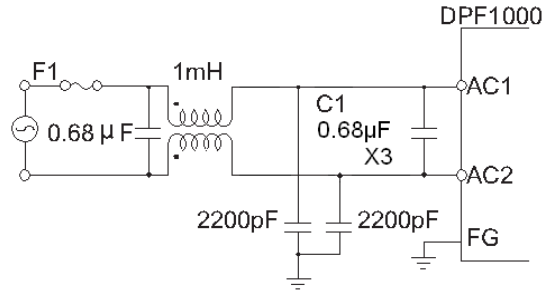

(3) External capacitor on the input side C1

- Install an external capacitor C1 as shown in Table 6.3.2 to reduce the line-noise and to keep stable operation of the module.

Use a film capacitor with rated AC250V to meet the safety standards.

Rated ripple current must be more than Fig.6.3.3.

Table 6.3.2  
External capacitor on  
the input side

No	Module	Capacitance	Recommended capacitor
1	DPA500F	0.47μF min	OAKAYA RE series
2	DPF1000	2μF min	

Fig.6.3.3  
Ripple current C1

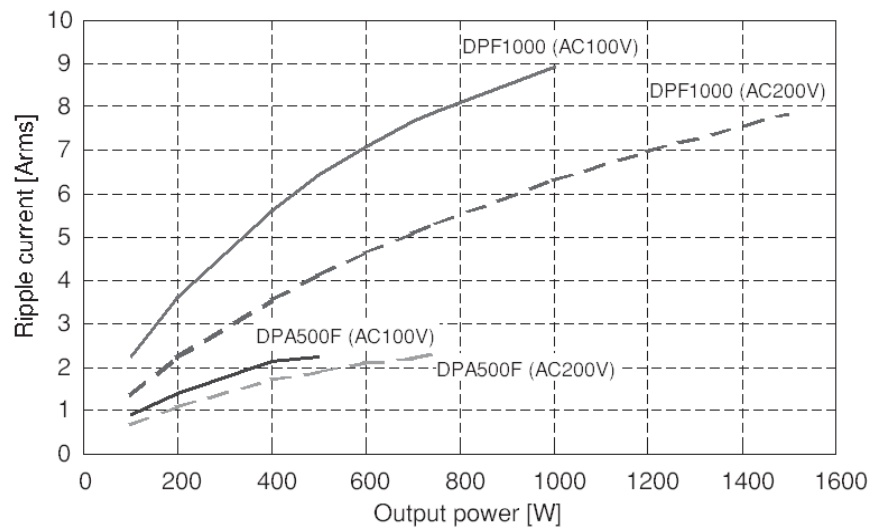

## 6.3.2 Wiring output pin

### (1) External capacitor on the output side C2

- Install an external capacitor C2 as close as possible to the output pins for stable operation of the module.

Use a film capacitor with rated over DC400V.

Rated ripple current must be more than Fig.6.3.4.

Recommended capacitance of C2 is shown in Table 6.3.3.

Table 6.3.3  
External capacitor on the output side

No	Module	Capacitance	Recommended capacitor
1	DPA500F	0.1 $\mu$ F min	OAKAYA RE series RUBICON MMW-HP series
2	DPF1000	1 $\mu$ F min	

Fig.6.3.4  
Ripple current C2

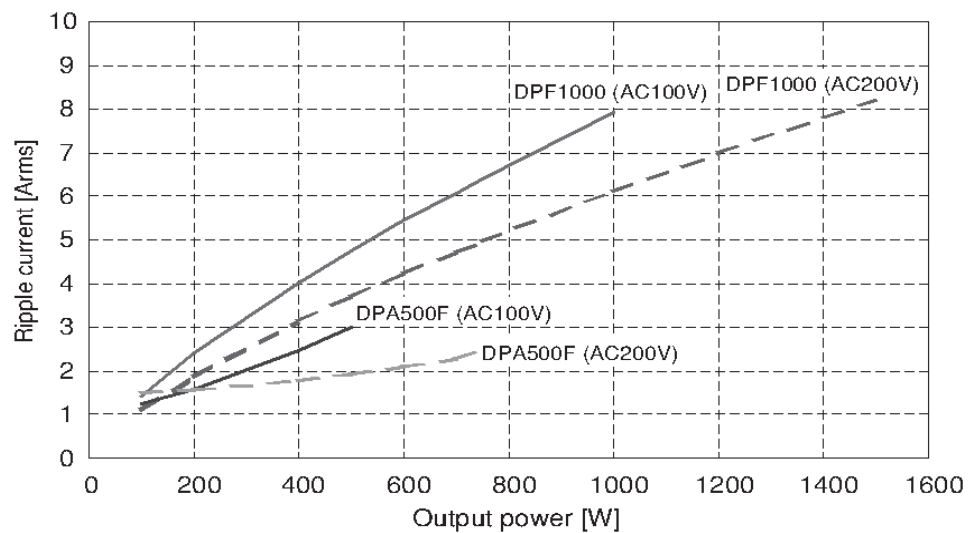

### (2) Decoupling capacitor C4

- Install a decoupling capacitor C4, as shown in Table 6.3.4, as close as possible to the output pins for stable operation of the module. Use the Y capacitor with rated AC250V to meet the safety standards.

Table 6.3.4  
Decoupling capacitor

No	Module	Capacitance
1	DPA500F	1000pF min
2	DPF1000	2200pF min

### (3) Holdup capacitor C3

- DPF1000 and DPA500F do not provide holdup capacitor.

Connect the electrolytic capacitor near the output pins.

Follow the guidelines below to select an electrolytic capacitor with an appropriate capacitance and ripple current rating considering the output ripple voltage, holdup time and life.

- The capacity should be with in range of Table 6.3.5.

Do not exceed the total capacity shown in Table 6.3.5 including capacitance of back-end.

It may cause severe damage.

Table 6.3.5  
Holdup capacitor

No	Module	Capacitance
1	DPA500F	120 - 1000 $\mu$ F
2	DPF1000	220 - 2200 $\mu$ F

i Design procedure of holdup capacitor

1) Output ripple voltage

Obtain the required capacity from the output ripple voltage.

Make sure that the output ripple voltage is less than 15Vp-p.

$$C_o \geq \frac{P_o}{2 \pi f \times V_{rpl} \times V_o} \quad \cdot \cdot \cdot \cdot \cdot \quad (1)$$

- C<sub>o</sub> : Capacitance of the holdup capacitor [F]
- V<sub>rpl</sub> : Output ripple voltage [Vp-p]
- P<sub>o</sub> : DPA500F, DPF1000 output power [W]
- f : Input frequency (50Hz/60Hz) [Hz]
- V<sub>o</sub> : Output voltage (Refer to Fig.6.3.5) [V]

2) Holdup time

Obtain the required capacity from the holdup time required for the system.

$$C_o \geq \frac{2 \times P_o \times T_h}{(V_o - V_{rpl}/2)^2 - V_{min}^2} \quad \cdot \cdot \cdot \quad (2)$$

- C<sub>o</sub> : Capacitance of the holdup capacitor [F]
- T<sub>h</sub> : Holdup time [S]
- P<sub>o</sub> : DPA500F, DPF1000 output power [W]
- V<sub>o</sub> : Output voltage (Refer to Fig.6.3.5) [V]
- V<sub>rpl</sub> : Output ripple voltage [Vp-p]
- V<sub>min</sub> : Minimum input voltage of DC-DC converter [V]

3) Ripple current

Obtain the required capacity from the holdup time required for the system.

(3) to calculate the total ripple current. Use a capacitor with the ripple current rating above the resulting value. Since the correction factor of allowable ripple current frequency (K) varies depending on the capacitor, check the exact value in the catalog of the capacitor.

$$I_r = \sqrt{I_L^2 + (I_H / K)^2} \quad \cdot \cdot \cdot \cdot \cdot \quad (3)$$

- I<sub>r</sub> : Ripple current flowing into the holdup capacitor [Arms]
- I<sub>L</sub> : Low frequency ripple current (Refer to Fig.6.3.6) [Arms]
- I<sub>H</sub> : High frequency ripple current (Refer to Fig.6.3.6) [Arms]
- K : Correction factor of the allowable ripple current frequency

Fig.6.3.5  
Output voltage  
(Actually measured  
data)

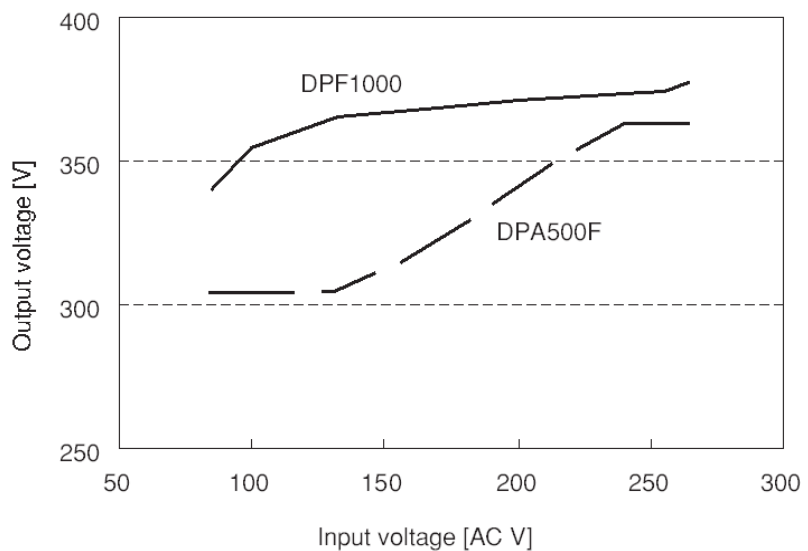

# DPF and DPA series

Fig.6.3.6  
Output ripple current

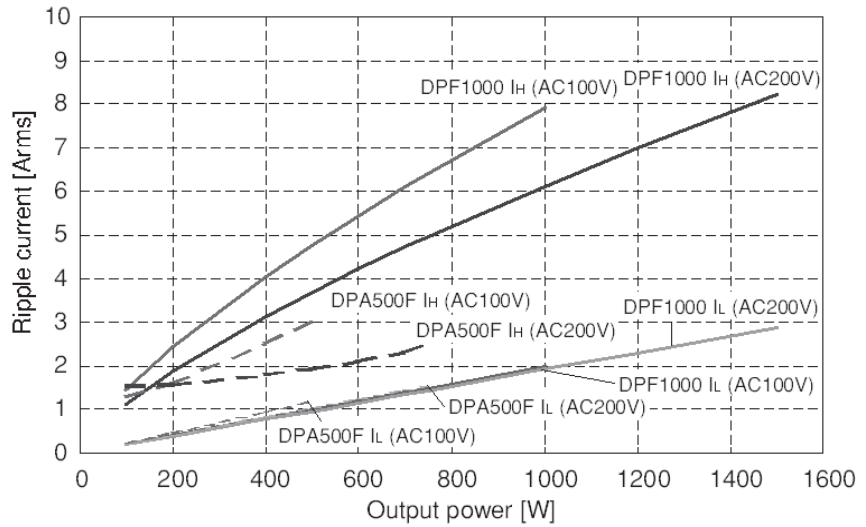

4) Selection of electrolytic capacitor

Use the electrolytic capacitor which meets the capacitance calculated in (1) and (2) above and the ripple current rating obtained in (3). When selecting the electrolytic capacitor, take into consideration the tolerance of the capacitor. Note that an electrolytic capacitor has a limited lifetime. The lifetime of the electrolytic capacitor is determined by the capacitor temperature, which can be estimated by the formula (4) below. To improve the reliability of the system, select an electrolytic capacitor which has a long enough lifetime (Lo).

$$(T_o - T_x) / 10$$

$$L_x = L_o \times 2^{\dots} \quad (4)$$

- Lx : Expected life time [H]
- Lo : Guaranteed lifetime of the electrolytic capacitor [H]
- To : Maximum rated operating temperature Lo [°C]
- Tx : Electrolytic capacitor temperature for use [°C]

5) Example calculation result

The following values are calculated in a similar manner :

Table 6.3.6  
Example of holdup capacitor

№	Module	Front-end output power	AC100V, TH=20mS		AC200V, TH=20mS	
			Co	Ir	Co	Ir
1	DPA500F	250W	270µF min	1.6A	220µF min	1.4A
2		500W	560µF min	2.5A	390µF min	1.8A
3		750W	-	-	560µF min	2.4A
4	DPF1000	1000W	680µF min	6.0A	680µF min	4.8A
5		1500W	-	-	820µF min	6.6A

This example is calculated as K=1.4

(4) Inrush current limiting resistor R1

- Use of the following pins (SR or R) will reduce the inrush current when AC input voltage is applied. They prevent blowing the input fuse, welding of the switches and relays, and cutting off the no-fuse-breaker. Note either of the following pins must be connected to the +V pin to start the unit.
- R pin  
 In order to set the inrush current at desired level, connect an inrush current limiting resistor R1 between the R pin and the +V pin, and open the SR pin. Also, use the resistor which has a capacity to withstand a large enough surge and which has a built-in thermal fuse. Consult to your parts manufacturer regarding the surge current withstanding capacity of the external resistor.
- SR pin (for DPA500F only)  
 By connecting the SR pin and the +V pin, the inrush current can be reduced when the AC input voltage is applied. The interval the AC input ON/OFF must be more than 7 seconds each time the AC input is applied.

Fig.6.3.7  
Inrush current limiting circuit using an external resistance R1

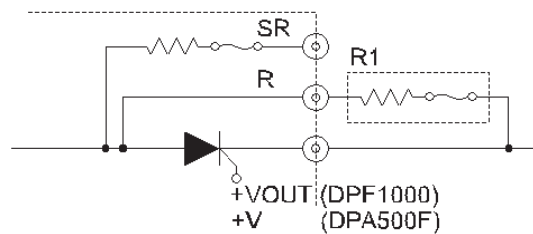

Fig.6.3.8  
Inrush current limiting circuit using the SR pin

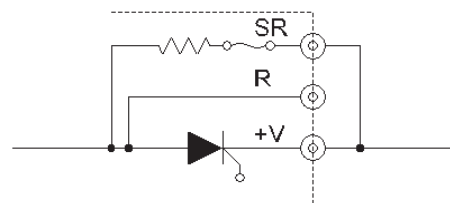

Table 6.3.7  
Example of inrush current limiting resistor

№	Module	Front-end output power	Holdup capacitor Co	Inrush current limiting resistor R1	Inrush current	
					AC100Vin	AC200Vin
1	DPA500F	250W	470μF min	10Ω	15A typ	30A typ
2		500W	1000μF min	10Ω	15A typ	30A typ
3		750W	1000μF min	10Ω	15A typ	30A typ
4	DPF1000	1000W	2000μF min	4.7Ω~10Ω	30A typ	60A typ
5		1500W	2000μF min	4.7Ω~10Ω	30A typ	60A typ

Note: Use the resistor which has a capacity to withstand a large enough surge and which has a built-in thermal fuse.

- The overcurrent protection circuit is not built-in. In order to secure the safety of the unit, use the normal-blow type fuse as shown in Table 6.3.8 on the output line.

Table 6.3.8  
Output fuse

№	Module	Recommended fuse
1	DPA500F	10A / DC400V
2	DPF1000	10A / DC400V

## 6.4 Function

### 6.4.1 Protection circuit

#### (1) Overcurrent protection

- The overcurrent protection circuit is not built-in.

In order to secure the safety of the unit, use the normal-blow type fuse as shown in Table 6.3.8 on the output line.

#### (2) Overvoltage protection

- The overvoltage protection circuit is built-in. The AC input should be turned off if overvoltage protection is activated. The minimum interval of AC ON/OFF for recovery is a few minutes which output voltage drops below 20V.

When this function operates, the power factor corrector function does not operate, and output voltage becomes the full-wave rectified AC input voltage.

- Remarks :

Please note that the unit's internal components may be damaged if excessive voltage (over rated voltage) is applied to output terminal of power supply. This could happen when the customer tests the overvoltage protection of the unit.

#### (3) Thermal protection

- Thermal protection circuit is built-in and it works at 100t15 at base plate.

When this function operates, the power factor corrector function does not operate, and output voltage becomes the full-wave rectified AC input voltage.

- When this function is activated, input voltage should be turned and remove all possible causes of overheating, and cool down the temperature to normal level. To prevent the unit from overheating, avoid using the unit in a dusty, poorly ventilated environment.

### 6.4.2 Control signals

#### (1) Inverter operation monitor (IOG)

- IOG can be used for monitoring failures such as redundant operation.
- Use IOG to monitor operation of the inverter. In the case of abnormal operation, status is changed from "L" to "H" within one second.
- IOG may become unstable in case of start-up or sudden change of load current. Set the timer with delay of more than five second.
- During parallel operation, unstable condition may occur when load current becomes lower than 10% of rated value. (for DPF1000 only)
- The sequence of the IOG signal is shown in Fig.6.1.5.

Fig.6.4.1  
IOG pin

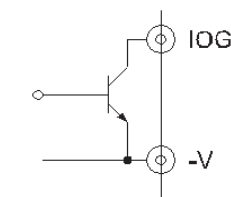

(2) Enable signal (ENA) /Power Ready signal (PR)

- Use ENA or PR to control starting of the power supply as load.
- When inrush current protection circuit is released, ENA outputs "LOW".
- When inrush current protection circuit is released, PR outputs "LOW".
- If load current flows without releasing of the circuit, the resistor may be burnt.

Fig.6.4.2  
ENA / PR pin

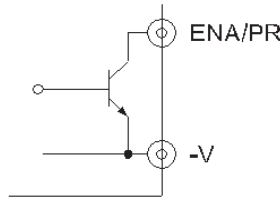
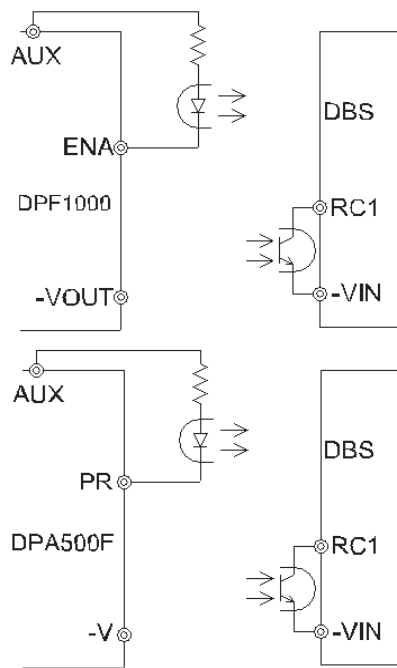

Fig.6.4.3  
Example of connection  
to the DBS



(3) Auxiliary power supply circuit for external signal (AUX)

- The AUX pin can be used as the power source with the open collector output for IOG and ENA.
- When used with AUX pin of additional units of this model for parallel connection, make sure to install a diode and that the maximum output current must be up to 10mA.
- The AUX pin of DPA500F and DPF1000 are not able to connect in parallel. It may damage the unit.
- Never let a short circuit between the AUX pin and other pins. It may damage the unit.

Table 6.4.1  
Auxiliary power supply  
circuit for external  
signal

No	Module	Output voltage	Maximum output current
1	DPA500F	DC10 - 20V	10mA max
2	DPF1000	DC6.5 - 8.5V	10mA max

## 6.4.3 Others

(1) Isolation

- For a receiving inspection, such as Hi-Pot test, gradually increase (decrease) the voltage for a start (shut down). Avoid using Hi-Pot tester with the timer because it may generate voltage a few times higher than the applied voltage, at ON/OFF of a timer.

## 6.5 Series and parallel operation

### 6.5.1 Series operation

- As input and output are not isolated, series operation is not possible.

### 6.5.2 Parallel operation

- Parallel operation is available by connecting the units as shown in Fig.6.5.1 or Fig.6.5.2.
- As variance of output current drew from each power supply maximum 10%, the total output current must not exceed the value determined by the following equation.  
(Output current in parallel operation) = (the rated current per unit) x (number of unit) x 0.9
- When the output-line impedance is high, the power supply become unstable. Use same length and thickness (width) wire (pattern) for the current balance improvement.
- Install an external capacitor C2 near the output pins for stable operation of the module.
- Connect between the input pins of each module for the lowest possible impedance. When the number of the units in parallel operation increases, input current increases. Adequate wiring design is required for input circuitry such as circuit pattern, wiring and load current.
- If temperatures of aluminum base plates are different in the power supply for parallel operation, output current will change greatly. Please note to equalize plate temperatures by attaching the same heat sinks.
- Output diode Di is not required if total holdup capacitor in parallel connection is smaller than value of below table.

Table 6.5.1  
Output capacitance of  
Di non-required

No	Module	Total output capacitance
1	DPA500F	1000 $\mu$ F max
2	DPF1000	2500 $\mu$ F max

- In parallel operation, please connect diode to the +side of the output circuit. If diode is connected to the -side, it will damage the unit or/and, the balancing function will not work.

# DPF and DPA series

Fig.6.5.1  
Connection for parallel  
operation (DPA500F)

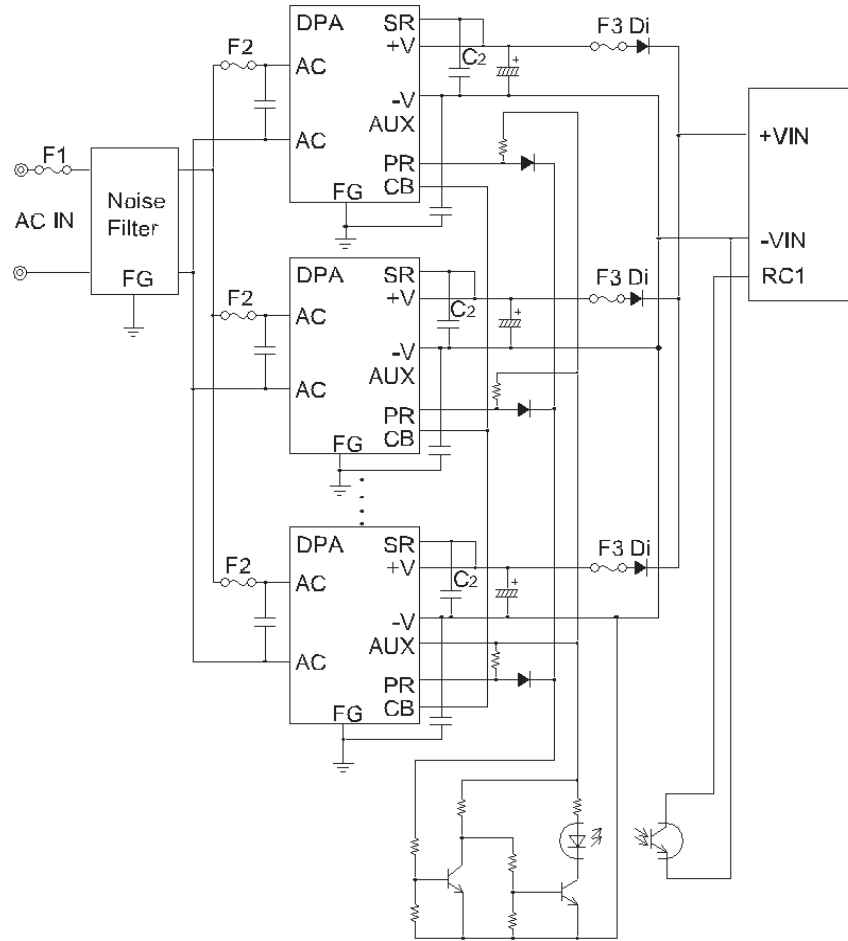
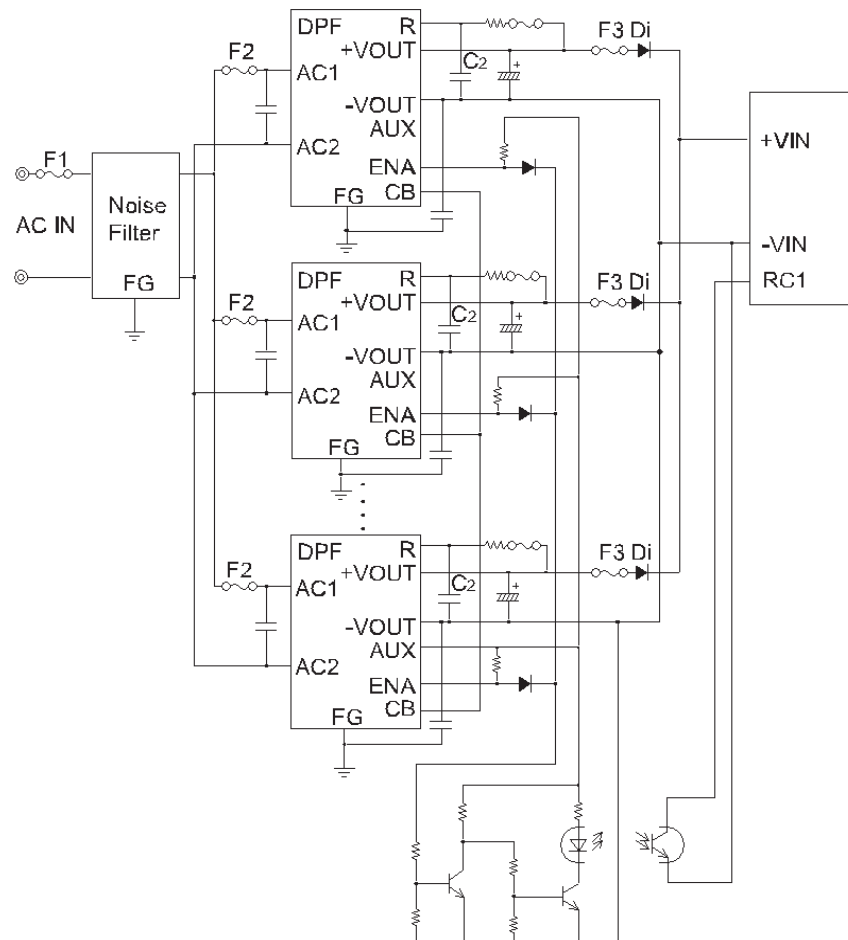

Fig.6.5.2  
Connection for parallel  
operation (DPF1000)



## 6.5.3 N+1 redundant operation

- DPF1000 provide set N+1 redundant operation for improving reliability of power supply system. Connect as shown in Fig.6.5.3.
- Purpose of redundant operation is to ensure stable operation the event of single power supply failure. Since extra power supply is reserved for the failure condition, so total power of redundant operation is equal to N.
- DPA500F dose not provide N+1 redundant operation.

Fig.6.5.3  
N+1 redundant  
operation (DPF1000)

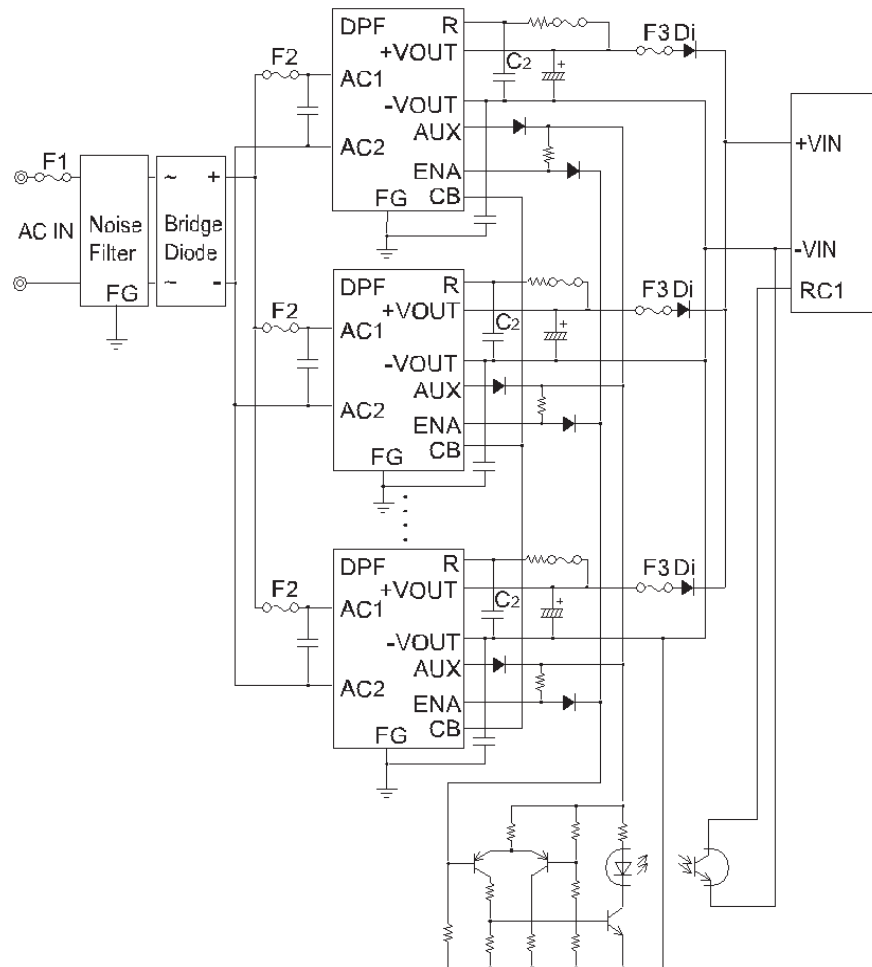

## 6.6 EMI

- The recommended circuit to meet noise standard CISPR Pub.22.
- The noise may vary greatly, depending on the implementation, being affected by the stray capacity, wiring inductance and leakage flux. Check if the noise filter is appropriate on the final product.

# DPF and DPA series

Fig.6.6.1  
Recommended filter  
(DPA500F)

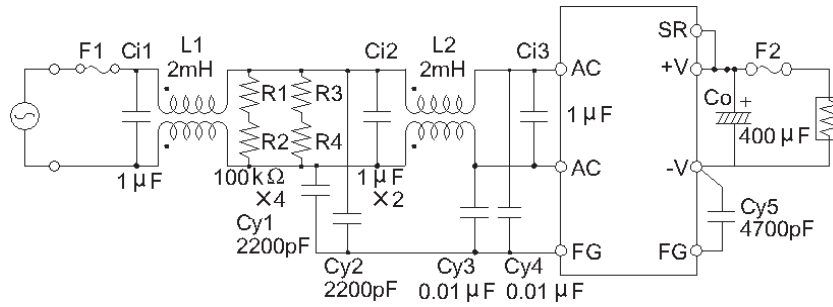

Ci1, Ci2, Ci3 : 1.0µF (RE series : OKAYA)  
 Cy1, Cy2 : AC250V 2200pF (KH series : MURATA)  
 Cy3, Cy4 : AC250V 0.01µF (KH series : MURATA)  
 Cy5 : AC250V 4700pF (KH series : MURATA)  
 L1, L2 : 2mH (SC series : TOKIN)

Fig.6.6.2  
Noise level (DPA500F)

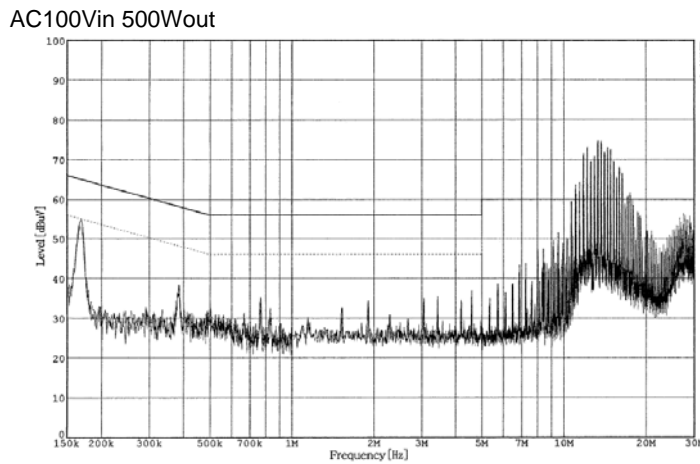
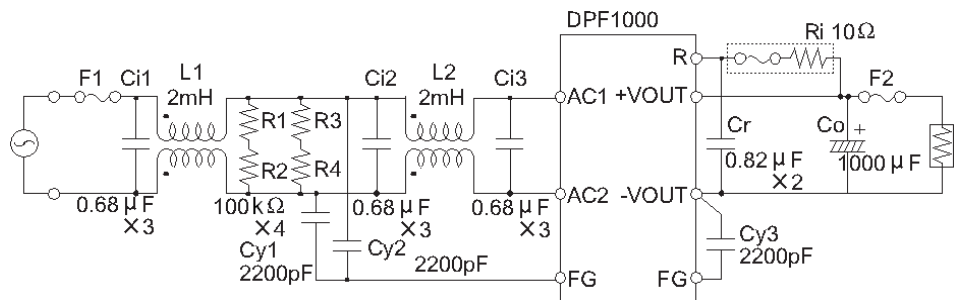

Fig.6.6.3  
Recommended filter  
(DPF1000)



Ci1, Ci2, Ci3 : 0.68µF (RE series : OKAYA)  
 Cy1, Cy2, Cy3 : AC250V 2200pF (KH series : MURATA)  
 L1, L2 : 2mH (SC series : NEC TOKIN)

Fig.6.6.4  
Noise level (DPF1000)

